

Electrically controllable 100 GHz band reflectarray with double layer patch using nematic liquid crystal

Hiroshi Moritake, and Yo Inoue

moritake@nda.ac.jp

National Defense Academy, 1-10-20 Hashirimizu, Yokosuka, Kanagawa 239-8686, Japan

Keywords: milliwave, terahertz wave, phase array antenna, reflectarray, liquid crystal, aligned microfiber

ABSTRACT

Double layer patch element, which is added to an additional patch layer above dielectric layer, using nematic liquid crystal for 100 GHz band electrically tunable reflectarray is proposed. The maximum phase change is achieved to 360 degrees and the frequency range of over 360 degrees is between 90.5 GHz and 120 GHz. Phase change characteristics in this element are independent of the polarization of the incident wave and it is advantage for the application of the reflectarray.

1 Introduction

The growth in the demand for high speed and high-capacity communication is evident with the development of wireless technology. At the same time, mobile communication frequency band expands with each new generation, and the frequency will expand up to 90 GHz in the 5G communications and 300 GHz in the 6G communications. However, the utilization of higher frequency bands introduces a significant challenge which is an increased occurrence of coverage holes due to high straightness. The reflectarray emerges as an effective method, offering cost and time savings compared to constructing new base stations. The concept revolves around reflecting radio waves from existing base stations to the coverage holes, providing a technically feasible solution to enhance communication range, rather than relying on directly transmitted waves. We have already reported 100 GHz band reflectarray based on microfiber/liquid crystal composite[1,2], but in which the thickness of composite is extremely thick in 1 mm. For reducing the thickness of the liquid crystal layer with keeping large reflection phase, we propose that a double layer patch element is introduced. In this manuscript, we propose a double layer patch element using nematic liquid crystal for 100 GHz band electrically tunable reflectarray.

2 Experiment and Results

Before discussing the double layer patch element, the characteristics of the single layer patch element is expressed. Fig. 1 shows the analytical model of unit cell structure with single layer patch of the reflectarray. The length of the unit cell is 1.5 mm which is the half wavelength of 100 GHz in vacuum. The dielectric constant of liquid crystal ranges between 2.5 and 3.5, which corresponds to that is perpendicular and parallel to the LC

director. In this study, the phase difference of the reflection wave of the reflectarray with the LC dielectric constant between 2.5 and 3.5 is analyzed using

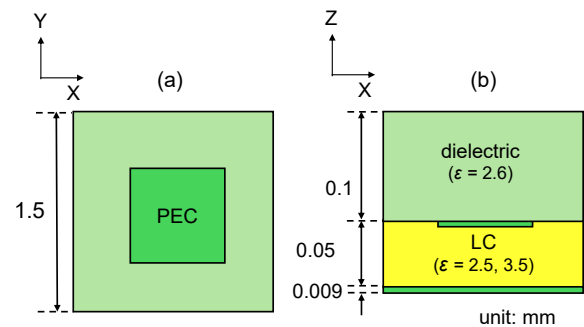

Fig. 1 (a) Top view and (b) side view of the reflectarray unit cell with single patch element.

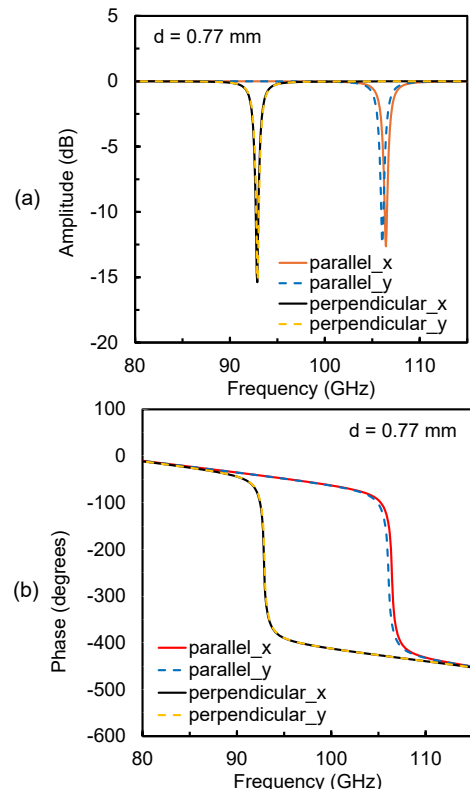

Fig. 2 Frequency dependences of (a) magnitude and (b) phase of reflection in simulation results with single patch element.

electromagnetic simulation software (SIMULIA, CST Studio Suite).

Fig. 2 shows simulated reflection coefficients of the reflectarray with single patch element with length of 0.77 mm, with variations in the liquid crystal dielectric constant. In this figure, 'parallel' is denoted as the direction of the liquid crystal orientation parallel to the substrate along the x-axis and 'perpendicular' is denoted as the direction of that perpendicular to the substrate along the z-axis. Furthermore, 'x' means that the electric field direction in the incident wave is along the x-axis and 'y' means that along the y-axis. It is evident that the resonant frequency shifts to the lower frequency side as the orientation direction of the liquid crystal changes from parallel to perpendicular to the substrate. Consequently, the phase shift follows the same trend, with the phase change at each frequency reaching its maximum value, equal to the difference between the phases at 2.5 and 3.5. And it is also confirmed that this phenomenon is independent of the electric field direction of the incident wave. From Fig. 2(b), it is confirmed that the maximum phase difference is 349 degrees, and the frequency range is between 93.5 GHz and 105.5 GHz with 90% of the maximum phase difference.

Fig. 3 shows the analytical model of unit cell structure with double layer patch of the reflectarray. In this structure compared with that with single layer patch, an additional patch is added to the top of the dielectric substrate. In the simulation of this study, we choose that the sizes of both patches are the same. Fig. 4 shows simulated reflection coefficients of the reflectarray with double patch element with length of 1.0 mm, with variations in the liquid crystal dielectric constant. In Fig. 4(a), it is confirmed that the number of the resonances increases. The lowest resonance frequency decreases compared to that with the single patch element as shown in Fig. 2(a). This phenomenon is considered to be caused by the increase of the patch size. Introducing an additional patch, the large phase difference in higher frequency range is recognized. The maximum phase difference is achieved to 360 degrees and the frequency range of over 360 degrees is between 90.5 GHz and 120 GHz. From these results, it is

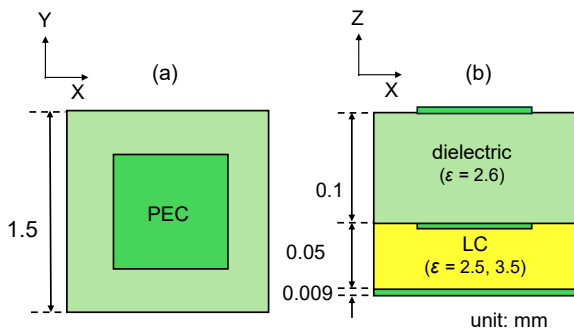

Fig. 3 (a) Top view and (b) side view of the reflectarray unit cell with double patch element.

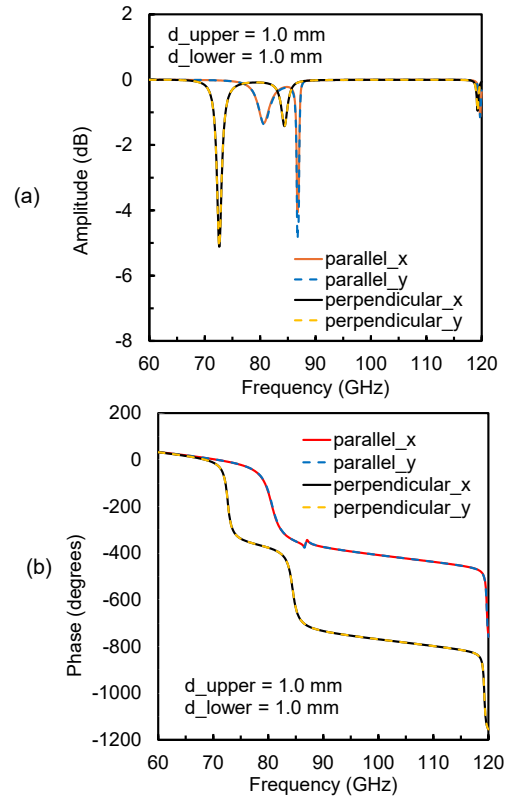

Fig. 4 Frequency dependences of (a) magnitude and (b) phase of reflection in simulation results with double patch element.

confirmed that the introduction of the double patch layer contributes to an increase in the amount of phase change and an expand of the frequency with large phase difference.

3 Conclusions

Double layer patch element, which is added to an additional patch layer above dielectric layer, using nematic liquid crystal for 100 GHz band electrically tunable reflectarray was proposed. The maximum phase change was achieved to 360 degrees and the frequency range of over 360 degrees was between 90.5 GHz and 120 GHz. Furthermore, in this element, the phase shift characteristics are independent of the polarization of the incident wave and is advantage for the application of the reflectarray.

REFERENCES

- [1] T. N. Lang, Y. Inoue, and H. Moritake, *IEICE Com. Ex.*, Vol. 13, pp. 235-239 (2024).
- [2] H. Moritake, and Y. Inoue, *Proc. of IDW'24*, Vol. 31, pp.50-51 (2024).