

# A New Pump Design for Gasoline Dispenser at The Service Station

Yajun Liu\*, Jiakun Ye\*, Wenhua Xie\*, Shuyan Zhan\*

\*School of Mechanical and Automotive Engineering, South China University of Technology  
Guangzhou, Guangdong, 510640 China  
(E-mail: corresponding\_authors\_yajun@scut.edu.cn)

**Abstract:** In order to improve the efficiency of gasoline dispenser, a new vane pump design is proposed. It is a hollow vane that aims to reduce the cavitation and increase the efficiency. In the paper explanation about force is given to account for the design. Contrast experiments are carried out to demonstrate the performance of the new pump. On the basis of the experimental data, the volumetric efficiency of pump and total efficiency of system are better than the old one. What's more, a mathematical model is established to investigate the effect of clearances' thickness on the distribution of dead-zone pressure. Results show that the clearance of stator-rotor is of great importance to the dead-zone pressure.

**Keywords:** Gasoline, New pump, Structure, Efficiency, Pressure

## INTRODUCTION

Dispenser that mainly comprises of pump, motor, flowmeter and nozzle is a refueling terminal which injects fuel into tank of automobile at the service station. Compared to diesel, gasoline is a volatile medium with much lower viscosity causing low efficiency of its' pumping system. According to the experiments, the pumping efficiency of system is usually no more than 25% [1]. Even if the efficiency is low and thousands tons of fuel is refueled into vehicles' tank each day, a little investigation is focused on the efficiency of fuel dispenser. With the variable speed technique, the efficiency of system can be improved at last 20% by optimizing systems' control strategy[2]. In fact, the pump of dispenser plays an important role in the system, but there has been little research about fuel pump, since it was invented [3]. As for the pump used at the service station, it should keep the vacuum of pump between -40000 to -30000Pa. Because of this, cavitation that results in noise and low efficiency occurs easily.

Moreover, the mechanical contact between pump and motor leads to leakage easily. The leakage of gasoline not only pollutes environment but also causes danger to people around the station. However, as the development of magnetic coupling, this kind of leakage can be avoided completely. The magnetic coupling that is non-mechanical contact does transmit torque with magnetic force. Because of the good performance of seal, the magnetic driven devices have been used in danger industry such as chemical industry[4]. Though the technique of magnetic coupling is mature, a few dispenser works with magnetic driven pump. Due to the advantage of magnetic coupling, it should be assembled into the pump.

Hence, to improve the volumetric efficiency, total efficiency of system and avoiding leakage, a new vane pump with magnetic coupling and unique structure is proposed for gasoline.

In addition, the thickness of clearance has great effect on the efficiency of pump. For one thing, the clearance influences the volumetric efficiency and vacuum of pump. For another, it relates to the inner pressure distribution[5]. About the internal pressure distribution study of vane pump, Jang et al.[6-8] mainly established the pressure ripple, flow ripple and kinetics model as well as testing verification. In gear pump, trapping is a

deadly problem which limits its performance. To solve the problem, many of works about damping tank were done [9-10]. In regard to investigating the thickness of clearance to reduce the trapping problem, it is insufficient. Though the efficiency of pump is higher, trapping occurs.

Therefore, in this paper, the structure of the pump will be introduced firstly, and explanation will be presented. The characteristic of pressure under different thickness of clearance will be investigated by mathematical model.

## DESIGN OF NEW PUMP

### The Key Structure of Pump and Analysis

As is showed in fig.1, there is the major structure of new pump and the inner structure of pump is changed thoroughly. The medium will go through from inner stator to hollow vane and at last fuel will full of the chamber, when the pump is driven by the motor with magnetic coupling. It is different from traditional vane pump that sucks fuel from outer stator.

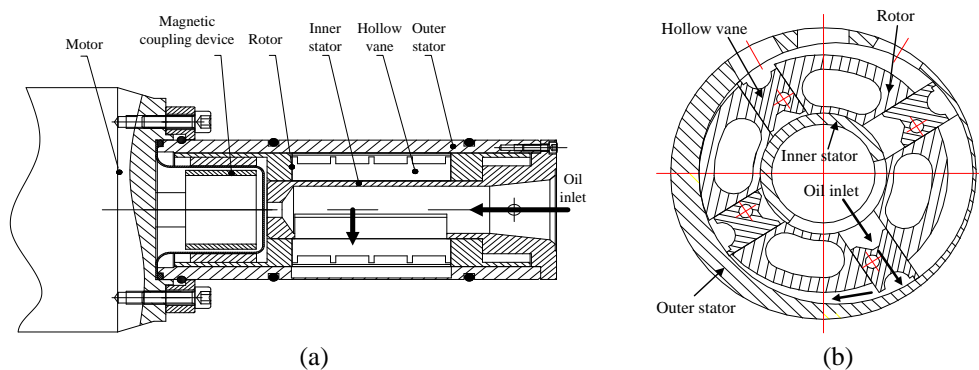

FIGURE 1. Primary Structure of New Vane Pump

The rotor is modified as showed in fig.1 and fig.2. The material of the rotor is copper and the material of inner stator is 41Cr4(ISO) as well as the outer stators' material. The cooperating style of them is hard-soft-hard (hardness of material) making sure that they don't stick each other as the thickness of clearance reduced. Experiments showed that if their cooperating style is hard-hard-hard, the pump will stick after it runs several minutes. Apart from vane-slot, there are four slots at the rotor. On the one hand, it is material saving. On the other hand, it helps to decrease the overshoot of dispenser. The weight of rotor is something to do with moment of inertia that affects the overshoot.

The vane is hollow like fig.2. A metal bar is assembled in the vane to add the weight of vane. The vane will paste to the wall of outer stator due to the centrifugal force and this distinguishes the common seal such as injecting the high pressure oil into the tail of vane or installing the follower ring at the rotor.

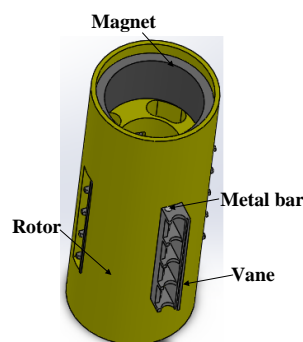

FIGURE 2. Structure of Rotor and Vane

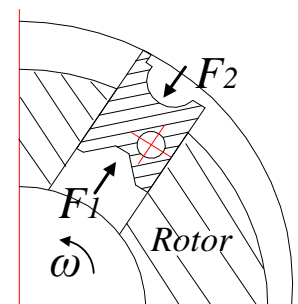

FIGURE 3. Hydraulic Pressure of Vane

In the structure, the force of vane is optimized. A simplified model is established as fig.3. Compared to force

of solid vane,  $F_1$  and  $F_2$  are equal as well as pressure 1 ( $P_1$ ) and pressure 2 ( $P_2$ ). Hence, the force and pressure can be ignored, so pressure impact on vane is eased or removed. It also makes the vane pasted wall of outer stator by centrifugal force tightly. It not only seals well, but also relieves wear between vane-tip. Force of traditional vane is  $F_t$  and that of new pump is  $F_n$ . Their comparison is showed as follow. Obviously,  $F_n$  is smaller than  $F_t$ . When calculating, pressure of dispenser is more than 250000Pa normally, and the length of vane is about 0.06m. The thickness of vane is 0.004m. For new pump, the speed of motor is about 22.5r/s, and radius of vane is 0.025m approximately.

$$F_t = PS = 250000 \cdot \frac{4}{1000} \cdot \frac{60}{1000} = 60N \quad (1)$$

$$F_n = Ml\omega^2 = \frac{10 \cdot 9.8}{1000} \cdot \frac{25}{1000} \cdot \left(\frac{2\pi \cdot 1350}{60}\right)^2 = 49N \quad (2)$$

What's more, the new structure is beneficial for oil flowing into the chamber, once the volume of chamber increases. It is helpful to reduce cavitation, save energy and increase volumetric efficiency. As a positive displacement pump, the pressure of chamber will be negative at low pressure area, so the oil will be sucked into chamber. In the process, there are centrifugal force and negative pressure working on the oil. In the new pump, the direction of oils' centrifugal force and force caused by negative pressure is the same, but it is opposite at the traditional vane pump. It means that more energy is consumed at traditional vane pump.

## Experiments and Results

The optimization aims to increase the efficiency of pump. Experiments are carried out to certify the higher efficiency of new pump. The tested medium is testing fluid (D80) that the viscosity is the same as diesel. The motor integrated with magnetic driven pump is 21.2(r/s)/370W, while the motor driving the traditional vane pump is 15.5(r/s)/550W. The displacement of new pump is  $4.96 \times 10^{-5} \text{m}^3/\text{r}$ , and that of the traditional vane pump is  $1.5 \times 10^{-4} \text{m}^3/\text{r}$ . Both of pumps are driven directly. In the tests, input power, output flow and pressure differential are measured. Results are showed as follow.

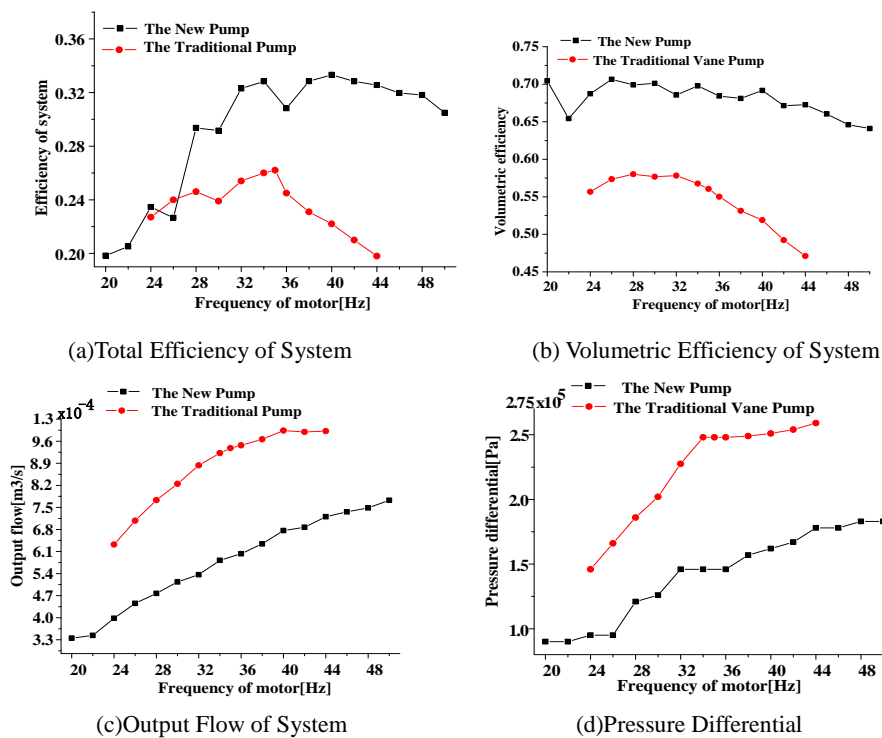

FIGURE 4. Relative Results of Tests

Curves at fig.4 (a) are the comparison of two pumps' efficiency. The efficiency of new pump is higher than the other, caused by the increase of volumetric efficiency as curves at fig.4(b). It conforms to the investigation that as for low viscosity pumping system, the efficiency of system is depended on volumetric efficiency primarily. Though the output flow of traditional pump is larger than the new pump, the volumetric efficiency is less. Because larger flow leads higher pressure and outflow at the same pipe condition. It means more leakage. In all, no matter the total or volumetric efficiency, the performance of new pump is better than the rest.

## CALCULATING THE DISTRIBUTION OF PRESSURE

### Mathematical Model of Dead-Zone Pressure

To study the internal pressure distribution of dead-zone, a mathematic model including speed, working pressure and thickness of clearance has been established.

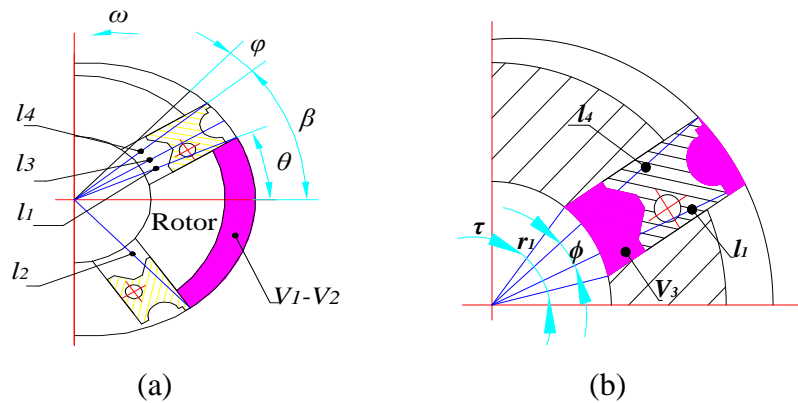

FIGURE 5. Key Parameters of Calculation

The deducing process is showed as follow.

$$l_1 = \sqrt{R^2 - e^2 \sin^2 \theta} + e \cos \theta \quad (3)$$

Where,  $R$  is the radius of outer stator,  $e$  stands for eccentricity,  $\theta$  represents the initial angle of the vane.

On the basis of the geometrical relationship of  $l_1$  and  $l_2$ ,  $l_2$  can be calculated. Therefore the changing rate of  $V_1$  is:

$$\frac{dV_1}{d\phi} = \frac{B}{2} (l_1^2 - l_2^2) \quad (4)$$

Where,  $B$  is the length of eccentricity cavity.  $V_1$  represents the volume of the chamber showed at fig.5(a).

There are two small triangles that included in  $V_1$ . The volume of them ( $V_2$ ) is:

$$V_2 = \frac{B}{2} ((l_1 - r)^2 + (l_2 - r)^2) * \cos \sigma \sin \sigma \quad (5)$$

Where,  $r$  is the radius of rotor,  $\sigma$  stands for the angle between two sides.

According to fig.5 (b), the calculation of volume  $V_3$  is Eq.(6).

$$V_3 = B \left( \frac{1}{2} l_3^2 \phi + r_1 l_4 \sin((\tau - \phi) / 2) - \frac{1}{2} r_1^2 \tau \right) - V_v \quad (6)$$

Where,  $r_1$  is the radius of inner stator,  $V_v$  is the volume of vane.

The schematic diagram is about the leakage of pump, and each of them is pressure-included leakage flow through the clearance. It is defined that leakage flow pushed into the chamber is negative. On the contrary it is

positive. Leakage flow is expressed by the following equation.

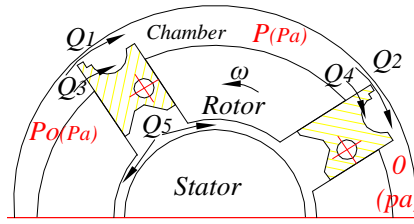

FIGURE 6. Schematic Diagram of Leakage Flow

$$\Delta q_1 = Q_2 - Q_1 = -\frac{B_1 h_1^3}{12\mu C_1} (P_o - 2P) \quad (7)$$

$Q_3$  and  $Q_4$  represent the axial leakage flow of vane, total leakage flow of this kind is  $\Delta q_2$

$$\Delta q_2 = 2(Q_4 - Q_3) = -\frac{B_2 h_2^3}{6\mu C_2} (P_o - 2P) \quad (8)$$

$$\Delta q_3 = Q_5 = \frac{B_3 h_3^3}{12\mu C_3} P \quad (9)$$

$$Q = \Delta q_1 + \Delta q_2 + \Delta q_3 \quad (10)$$

$$\frac{dV_L}{dt} = \frac{\omega dV_L}{d\phi} = Q \quad (11)$$

Where,  $\omega$  is the rotating speed.  $\mu$  represents the dynamic viscosity of oil.  $h_i$  stands for the height of clearance,  $B_i$  is the width of clearance,  $C_i$  is on behalf of length of clearance.

According to the compressible of oil, the relationship between pressure and volume of oil is showed as follow.

$$\frac{dp}{d\phi} = -\frac{k}{V_0} \frac{dV}{d\phi} \quad (12)$$

Where,  $k$  is the bulk modulus of elasticity.  $V_0$  is the initial volume.

Combining equations (4) to (12), there is

$$\frac{dp}{d\phi} = -\frac{k}{V_0} \left( \frac{dV_1}{d\phi} - \frac{dV_2}{d\phi} + \frac{dV_3}{d\phi} + \frac{Q}{\omega} \right) \quad (13)$$

LonggeKuta 45 is used to calculate in Matlab. Relative parameters are presented at table.1

TABLE 1 Relative Parameter

$k$	Bulk modulus of elasticity	1.16167e+9Pa	$R$	Radius of outer stator	0.029m
$\mu$	Dynamic viscosity	4.09e-04Pa*s	$r$	Radius of rotor	0.0265m
$\omega$	Angular velocity	141rad/s	$r_i$	Radius of inner stator	0.0135m
$p_o$	Output pressure	170000Pa	$e$	Eccentricity	0.0025m
$\phi$	Dead-zone angle	3.5°	$V_0$	Initial volume	1.66e-5m <sup>3</sup>
$B$	Length of eccentricity cavity	0.06m			

## Results and Analysis

The clearance of stator-rotor is changed from  $2 \times 10^{-5} \sim 4 \times 10^{-5} \text{ m}$  and others clearance included vane tip-outer stator, axial clearance of vane-rotor is changed as well. The thickness of clearance is commonly used at the design of fuel pump. The results are presented at fig.7.

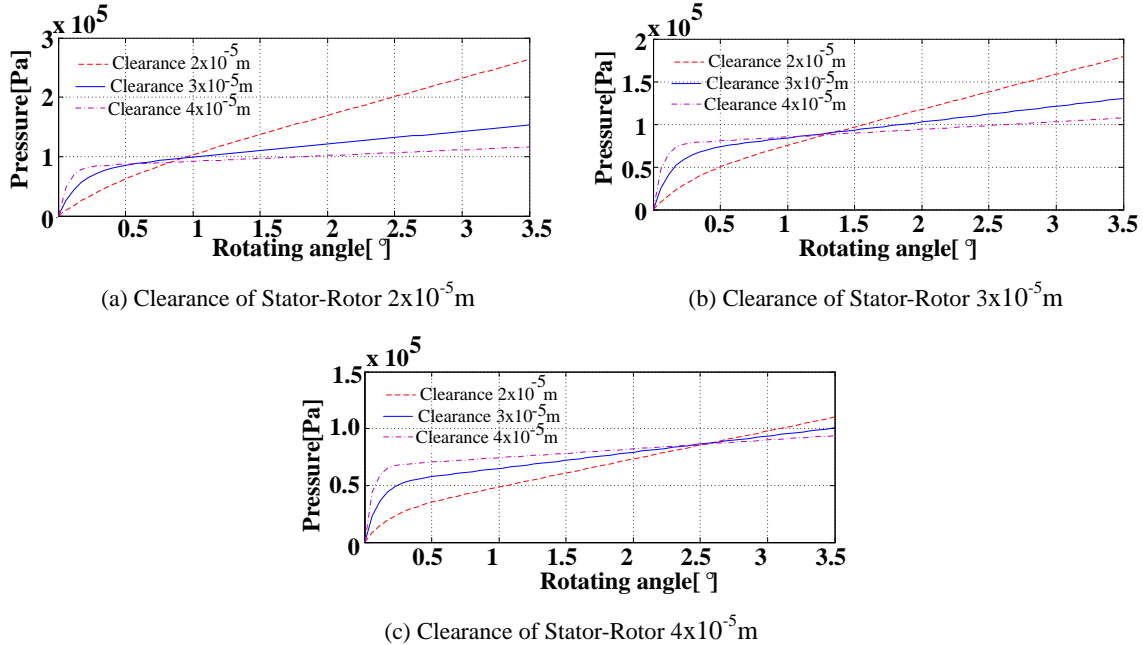

FIGURE 7. Pressure Distribution of Different Clearance

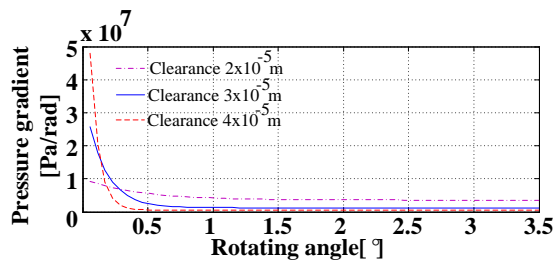

FIGURE 8. Pressure Gradient at Clearance of Stator-Rotor  $2 \times 10^{-5} \text{ m}$

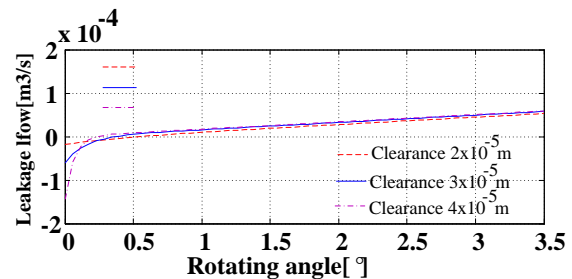

FIGURE 9. The Leakage Flow at Clearance of Stator-Rotor  $2 \times 10^{-5} \text{ m}$

As is showed at fig.7, no matter what clearance is in, the pressure rises up rapidly and increases steadily later. The pressure of clearance  $4 \times 10^{-5} \text{ m}$  is larger than the other, but it is the lowest at last, when the clearance of stator-rotor is invariable. The maximum pressure decreases obviously as the clearance of stator-rotor increased. That is to say that the effect of stator-rotor's clearance is greater than others. At each part of fig.7, curve of clearance  $2 \times 10^{-5} \text{ m}$  will exceed the rest, but it will take more time.

On the basis of curves at fig.8, the pressure gradient of different clearance at the clearance of stator-rotor  $2 \times 10^{-5} \text{ m}$  is quite different. Before  $0.5^\circ$ , the largest pressure gradient is at the clearance  $4 \times 10^{-5} \text{ m}$ , while the smallest one is at the clearance  $2 \times 10^{-5} \text{ m}$ . However, the situation inverts after  $0.5^\circ$ . The trend of the results at other stator-rotor clearance's pressure gradient is the same as curves of fig.8.

The situation like curves at fig.7 and 8 is something to do with the leakage flow. The more leakage flow, the lower pressure it will be. At fig.9, from the start, the value of leakage flow is negative meaning that the leakage flow is pushed into the chamber. The leakage flow is pushed into the chamber easily, so the pressure changes quickly at the beginning, when clearance increasing. The absolute value of leakage flow of curve clearance  $2 \times 10^{-5} \text{ m}$  is the smallest all the time so that the pressure is higher. The trend of leakage flow under other

stator-rotor clearance is the same as curves of fig.9.

## CONCLUSIONS

This work has focused on the low viscosity pumping system. Based on the characteristic of gasoline and the gasoline pumping system, a new design pump has been put forward. Investigation is done to focus on the force and pressure. The following conclusions are drawn.

To improve the seal and reduce the noise of system, the magnetic driven coupling was used at the new design. Low viscosity and cavitation of gasoline causes the low volumetric efficiency of system. Aiming to that, the inner structure was redesign at the new pump, and explanations about the design were given based on force. Results of the comparison tests showed the good performance of the new pump. Although the tested fluid was D80, it proved that the new design worked. However, as a new pump, there was more investigation needed to be done, such as flow regime of pump at gasoline medium, the flow ripple and pressure ripple and so on.

The clearance is of the great important to low viscosity pump. As the results of pressure model, the clearance of stator-rotor impacted the pressure greatly. Increasing the clearance could relieve the pressure impact effectively, but it also increased the inner leakage flow, and pressure gradient. It means that except the clearance of stator-rotor, other clearance of pump is as narrow as possible, if not, it has better to design a pressure groove to reduce the pressure impact.

## REFERENCES

1. Liu Y J, Tang D, Lumkes J J. Efficiency of pumping gasoline in service station[C]// Institute of Physics Publishing, 2012:2007.
2. Wan Q B, Liu Y J, Chen J M, et al. Frequency Conversion Pattern Design and Energy-saving Test of the Fuel Dispenser Pump System[J]. Chinese Hydraulics & Pneumatics, Vol.1, 2010,pp.14-16
3. [https://en.wikipedia.org/wiki/Fuel\\_dispenser](https://en.wikipedia.org/wiki/Fuel_dispenser)
4. Thompson K. What the future holds for magnetic drive pumps[J]. World Pumps, 2007, 2007(495):28-29.
5. Cantore, G., Paltrinieri, F., Tosetti, F., and Milani, M., "Lumped Parameters Numerical Simulation of a Variable Displacement Vane Pump for High Speed ICE Lubrication," SAE Technical Paper 2008-01-2445, 2008, doi:10.4271/2008-01-2445.
6. Jang J S, Kim K H, Cho M R, et al. The characteristics of pressure ripple in variable displacement vane pumps: Comparison between theory and experiment. Proceedings of the Institution of Mechanical Engineers Part A Journal of Power & Energy, 2002, 216(1):89-96.
7. Rundo M, Mancò S, Nervegna N, et al. Modelling and Simulation of Variable Displacement Vane Pumps for IC Engine Lubrication[C]// SAE World Congress. 2004.
8. Bianchini A, Ferrari L, Ferrara G, et al. Design and Optimization of a Variable Displacement Vane Pump for High Performance IC Engine Lubrication: Part 2 – Lumped Parameters Numerical Analysis[C]// Sae World Congress. 2009.
9. Lee, S. H., & Royston, T. J. (1997). Air-borne, fluid-borne and structure-borne noise radiation paths in a hydraulic power application equipped with a gear pump. In Proceedings - National Conference on Noise Control Engineering (Vol. 1, pp. 47-52). Inst of Noise Control Engineering.
10. Li Y, Liu K. Dynamic Model of Trapped Oil and Effect of Related Variables on Trapped Oil Pressure in External Spur-gear Pump[J]. Transactions of the Chinese Society for Agricultural Machinery, 2009, 40(9):214-219.